



Douglas E. Cade, PE, PS
County Engineer
1900 Lima Avenue
PO Box 828
Findlay, Ohio 45839-0828
419-422-7433

Hancock County Mail Box Policy

The Hancock County Engineer has a duty to provide safe, passable county roads for the traveling public. Mailboxes not in compliance with the U.S. Postal regulations are a safety hazard and an obstruction to the safe use of county roads. Please refer to the U.S. Postal Service mailbox size and placement requirements below. Ohio Revised Code §5547.03 provides for the removal of obstructions such as noncompliant mailboxes from the roads within Hancock County.

Mailbox Damage: Hancock County will repair or replace mailboxes damaged by **direct contact** with a county vehicle or by a county snow plow, **but not snow thrown from a plow**, while the vehicle performs county road maintenance or snow removal operations. Owners of damaged boxes must notify the Hancock County Engineer's Office which will inspect the damaged mailbox to confirm contact with a county road vehicle. A box that meets the minimum requirements, including size and cost, for the U.S. Postal Regulations shall be the replacement. Replacement location, height and distance from the pavement edge will also comply with U.S. Postal regulations.

To Report Damage: Please call 419-422-7433. A copy of this policy can be found at: <http://www.co.hancock.oh.us/government-services/engineer/permits> .

USPS Regulations Referenced

Mailbox Size Placement Requirements:

- 1) Your local postmaster must approve the location of your mailbox.
- 2) Put a roadside mailbox where a carrier can reach inside without leaving the truck. That means positioning it about 41" to 45" off the ground.
- 3) If you're mounting a curbside mailbox on a post near the street, the support should be secure and safe. The best supports are designed to bend or fall away if a car hits them.
- 4) The Federal Highway Administration recommends:
 - A wooden mailbox support no bigger than 4" x 4".
 - A 2"-diameter standard steel or aluminum pipe.
 - Bury your post no more than 24" deep, so it can give way in an accident.
 - Don't use potentially dangerous supports, such as heavy metal pipes, concrete posts and farm equipment, such as milk cans filled with concrete.
- 5) The unit shall be placed at an offset from the edge of the pavement so that the roadside face of the mailbox is no closer than 3' from the edge of the traveled lane. When a mailbox is

installed in the vicinity of existing guardrail, it shall be placed behind the guardrail unless otherwise approved by the County Engineer, by permit.

- 6) Multiple mailbox units of more than two boxes shall not be mounted on one support. However, lightweight newspaper boxes may be mounted below the mailbox on the side of the mailbox support. Multiple posts shall be placed no less than three feet apart, by permit.
- 7) Designs not described in this brochure will be acceptable only if written approval is granted by the County Engineer's Office.
- 8) The owner shall assume responsibility for and shall hold Hancock County harmless and defend any and all claims for personal injury and property damages that might be brought as a result of this work.
- 9) Mailboxes placed two feet behind curbs on subdivision streets with 25 m.p.h. speed limits are exempt from the previously stated requirements.
- 10) Brick or Stone Mailboxes are only permitted outside the right of way.

More information at: <https://www.usps.com/manage/mailboxes.htm>

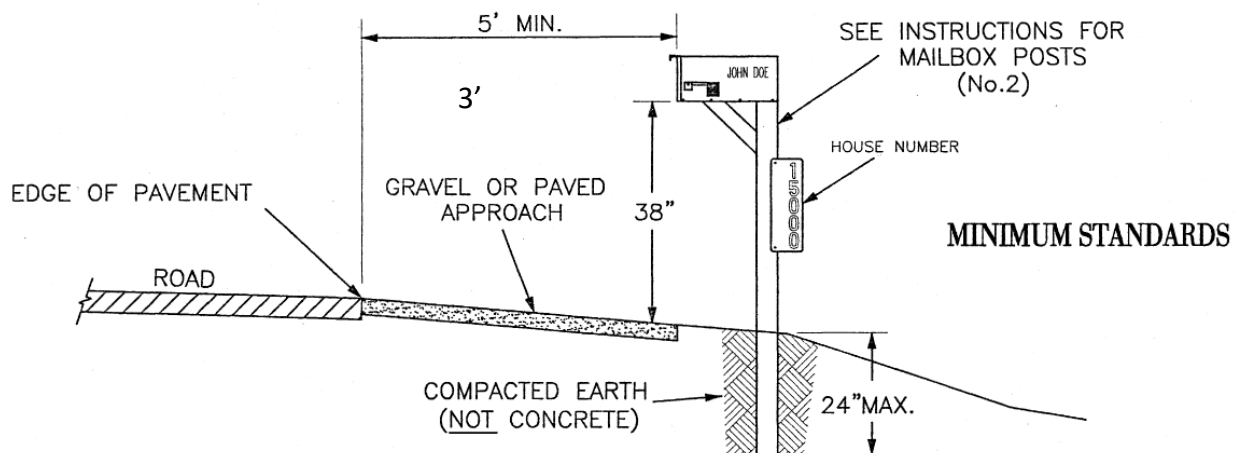

A full list of USPS mailbox specifications at:

<http://about.usps.com/publications/engineering-standards-specifications/spusps-std-7b01/welcome.html>

Effective January 25, 2019.

Douglas E. Cade, PE, PS
County Engineer